

Lesson 9 DHT11 Temperature and Humidity Sensor

Overview

In this tutorial we will learn how to use a DHT11 Temperature and Humidity Sensor.

It's accurate enough for most projects that need to keep track of humidity and temperature readings.

Again we will be using a Library specifically designed for these sensors that will make our code short and easy to write.

Component Required:

- (1) x Uno R3 Board
- (1) x DHT11 Temperature and Humidity module
- (3) x F-M wires (Female to Male DuPont wires)

Component Introduction

Temp and humidity sensor:

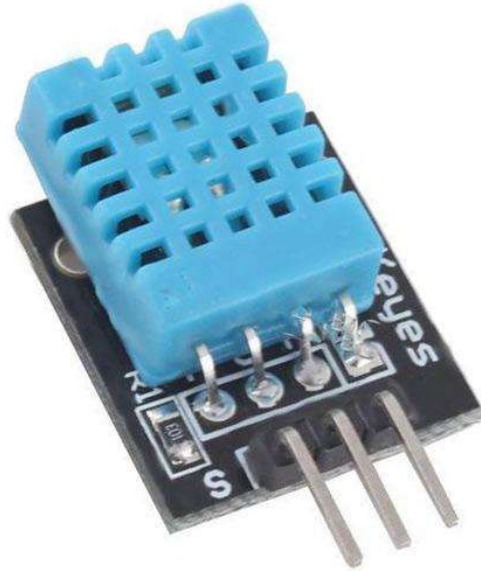

DHT11 digital temperature and humidity sensor is a composite Sensor which contains a calibrated digital signal output of the temperature and humidity. The dedicated digital modules collection technology and the temperature and humidity sensing technology are applied to ensure that the product has high reliability and

excellent long-term stability. The sensor includes a resistive sense of wet components and a NTC temperature measurement devices, and connects with a high-performance 8-bit microcontroller.

Applications: HVAC, dehumidifier, testing and inspection equipment, consumer goods, automotive, automatic control, data loggers, weather stations, home appliances, humidity regulator, medical and other humidity measurement and control.

Product parameters

Relative humidity:

Resolution: 16Bit

Repeatability: $\pm 1\%$ RH

Accuracy: At 25°C $\pm 5\%$ RH

Interchangeability: fully interchangeable

Response time: 1 / e (63%) of 25°C 6s

1m / s air 6s Hysteresis:

$< \pm 0.3\%$ RH

Long-term stability: $< \pm 0.5\%$ RH / yr in

Temperature:

Resolution: 16Bit

Repeatability: $\pm 0.2^\circ\text{C}$

Range: At 25°C $\pm 2^\circ\text{C}$

Response time: 1 / e (63%) 10S

Electrical Characteristics

Power supply: DC 3.5~5.5V

Supply Current: measurement 0.3mA standby 60 μA

Sampling period: more than 2 seconds

Pin Description:

1. the VDD power supply 3.5~5.5V DC
2. DATA serial data, a single bus
3. NC, empty pin
4. GND ground, the negative power

Connection Schematic

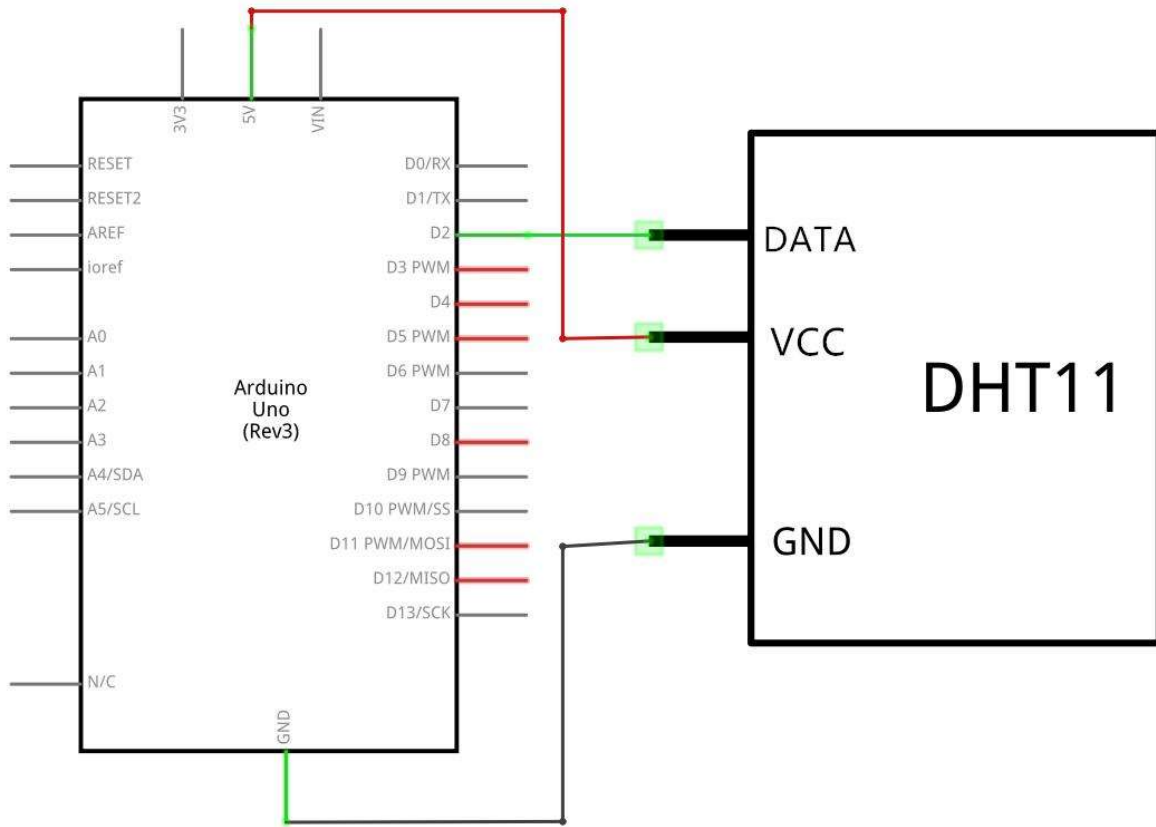

Wiring diagram

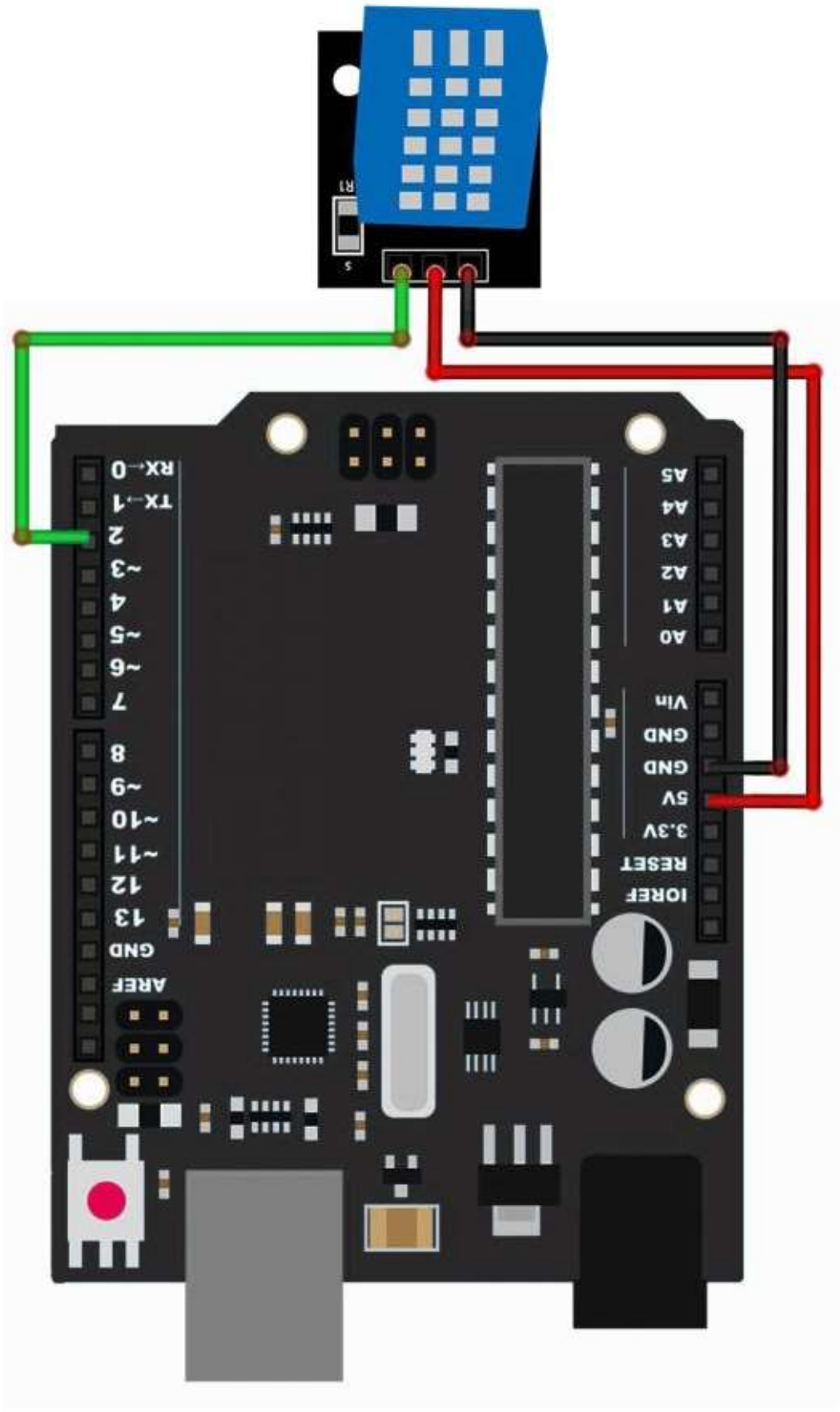

As you can see we only need 3 connections to the sensor, since one of the pin is not used.

The connections are: Voltage, Ground and Signal which can be connected to any Pin on our UNO.

Code

After wiring, please open the program in the code folder- Lesson 9 DHT11 Temperature and Humidity Sensor and click **UPLOAD** to upload the program. See Lesson 2 for details about program uploading if there are any errors.

Before you can run this, make sure that you have installed the < SimpleDHT> library or re-install it, if necessary. Otherwise, your code won't work.

For details about the tutorial on the loading of library file, see Lesson 1.

Example picture

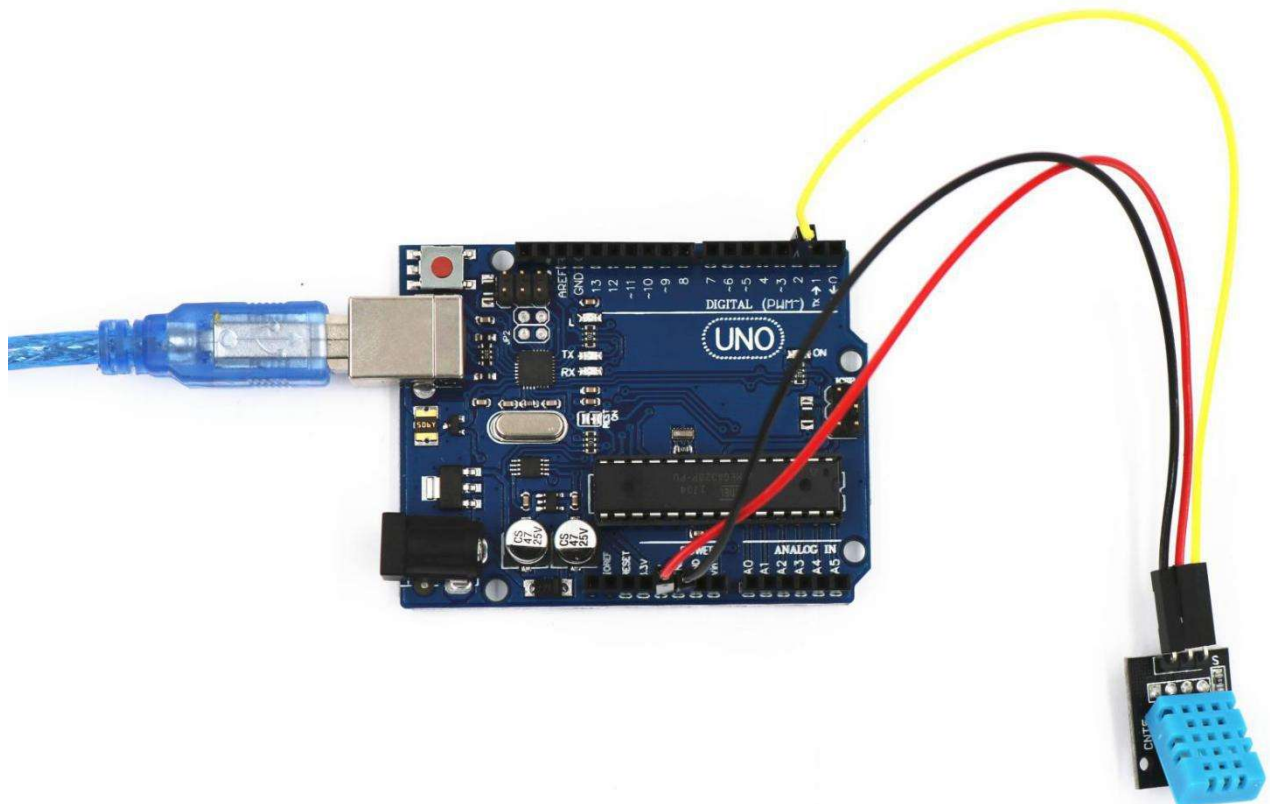

Upload the program then open the monitor, we can see the data as below: (It shows the temperature of the environment, we can see it is 22 degree)

[Click the Serial Monitor button to turn on the serial monitor.](#) The basics about the serial monitor are introduced in details in Lesson 1.

